

Burner systems:

- G45-2-GL-16/19-SS
- G45-2-GL-18-SS
- G45-2-GL-24-SS
- G45-2-GL-30-SS
- G45-2-GL-36-SS
- G45-2-GL-42-SS
- G45-2-GL-48-SS
- G45-2-GL-60-SS



**Unregulated burner system,
for use with natural gas only**

**FOR INSTALLATION IN
SEE-THRU SOLID-FUEL
BURNING FIREPLACES**

**FOR USE WITH
FYRE GLASS / FYRE GEMS**

G45-2-GL STAINLESS STEEL BURNER FOR OUTDOOR USE ONLY

Important: Read this manual carefully before starting installation of the burner system.

WARNING

If the information in this manual is not followed exactly, a fire or explosion may result, causing property damage, personal injury, or loss of life.

Do not store or use gasoline or other flammable vapors and liquids in the vicinity of this or any other appliance.

An LP-cylinder shall not be stored in the vicinity of this or any other appliance.

WHAT TO DO IF YOU SMELL GAS:

- Do not try to light any appliance.
- Do not touch any electrical switch; do not use any phone in the building.
- Immediately call the gas supplier from a neighbor's phone and follow the gas supplier's instructions.
- If you cannot reach the gas supplier, call the fire department.

Installation and service must be performed by an NFI Certified or other qualified professional installer, service agency, or the gas supplier.

CODE AND SUPPLY REQUIREMENTS

This outdoor burner must be installed in accordance with local codes and ordinances, or in the absence of local codes, with the latest National Fuel Gas Code, ANSI Z223.1.

 WARNING

Improper installation, adjustment, alteration, service, or maintenance can cause injury or property damage. Read the installation, operating and maintenance instructions thoroughly before installing or servicing this equipment.

This appliance is designed as an **attended appliance**. Adults **must** be present when the unit is operating. **DO NOT** leave this unit burning when unattended. If this product is left burning unattended it may cause damage or serious injury.

INSTALLER: Leave this manual with the appliance.
CONSUMER: Retain this manual for future reference.



TABLE OF CONTENTS

2	SAFETY INFORMATION
3	PARTS LIST
4	BEFORE YOU BEGIN - IMPORTANT INFORMATION
5	GLASS / GEMS QUANTITY DETERMINATION
6	INSTALLATION
6	INSTALLING THE BURNER
8	GLASS / GEMS PLACEMENT
8	BURNER PREPARATION
9	OPERATING THE BURNER SYSTEM - LIGHTING AND EXTINGUISHING
10	NOTES PAGE
11	CLEANING AND MAINTENANCE
11	MAINTENANCE
11	CLEANING
11	SERVICE
11	FLAME DESCRIPTION
12	TROUBLESHOOTING
14	WARRANTY

SAFETY INFORMATION

1. Children and adults should be alerted to the hazards of high surface temperatures and should stay away to avoid burns or clothing ignition.
2. Young children should be carefully supervised when they are in the area of the appliance.
3. Clothing or other flammable materials should not be placed on or near the appliance.
4. Any guard or other protective device removed for servicing the appliance must be replaced prior to operating the appliance.
5. Installation and repair must be done by a qualified professional service person. The appliance must be inspected before use and at least annually by a qualified professional service person. More frequent cleaning may be required as necessary.
6. Solid fuels shall not be burned in a fireplace where this burner system is installed.
7. Keep the appliance area clear and free from combustible materials, gasoline and other flammable vapors and liquids.
8. The burner assembly must be replaced prior to the appliance being put into operation if it is evident that the burner assembly is damaged. Contact your local dealer for replacement parts.
9. A fireplace screen must be in place when the system is burning. Provisions for adequate combustion air must be maintained. Unless other provisions for combustion air are provided, the screen shall have an opening(s) for introduction of combustion air. Combustion air is adequate when all flames curl into the fireplace and away from the screen. When a glass fireplace enclosure (door) is used, leave the doors fully open when the system is in operation.

PARTS LIST

Before installation, check that your gas burner system is complete. See the PARTS LIST below. If any parts are missing or damaged, contact your Real-Fyre® dealer before installing or using the burner. Be sure you know the model and size of your set when ordering options or replacement parts and accessories.

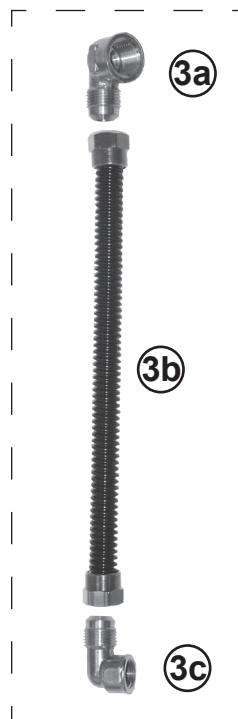
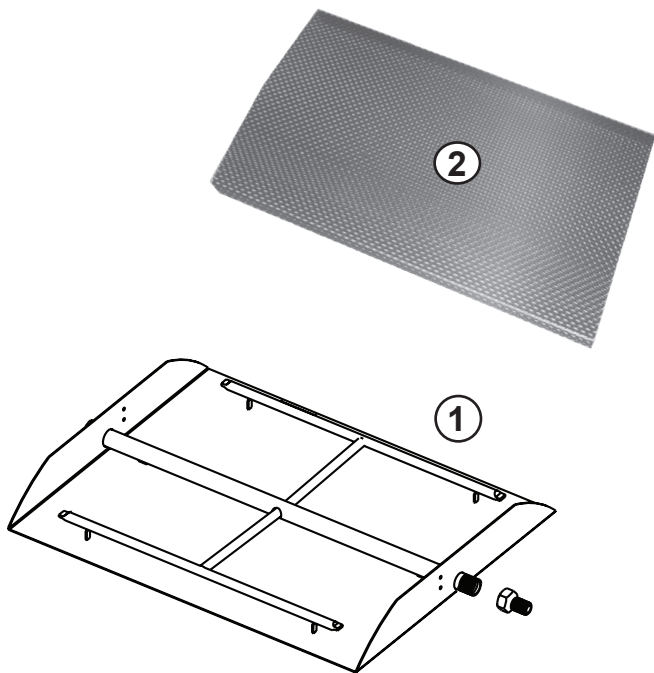

Replacement parts can be ordered from your local dealer.



All drawings & photos in this manual are not to scale.

ITEM	DESCRIPTION	QTY
1.	Burner pan	1
2.	Separator screen	1
3.	Connector kit (with adapters)	1
4.	Select sand granules	1
5.	Damper clamp	1

Fyre glass / Fyre gems are purchased and packaged separately. Quantity will vary, depending on selection. Glass and gems are available in various colors; contact your dealer for further details.

BEFORE YOU BEGIN - IMPORTANT INFORMATION

Before You Begin, review the information and safeguards below about the installation and operation of the Real-Fyre® gas burner system.

Check to be sure that the fireplace meets the venting and construction requirements for the installation of the Real-Fyre® burner system.

THIS BURNER IS DESIGNED FOR USE WITH NATURAL GAS. Never use propane gas in this burner.

Be sure the burner system is properly sized for the fireplace. Improper sizing may negatively impact the proper drafting of the fireplace. Fig. 4-1 illustrates the critical dimensions of the firebox.

This burner system must be installed by an NFI Certified or other qualified professional installer. The Real-Fyre® burner system is to be installed only in a solid-fuel burning fireplace with a working flue and constructed of noncombustible material. The fireplace must have an open damper. The chimney must be free of any obstructions.

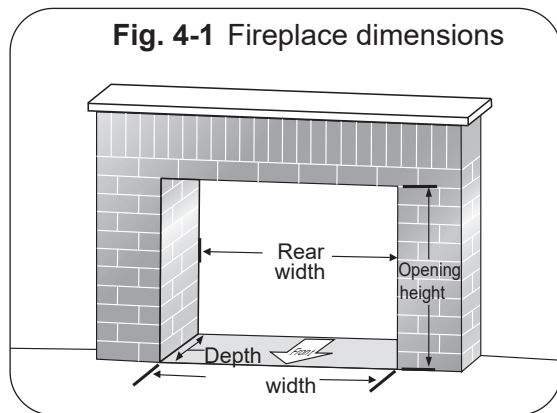

The fireplace must have a gas supply line that has been installed by a qualified technician in accordance with all local codes. The gas supply line must have a ½" minimum interior diameter. If the gas line to the fireplace is longer than 20', a larger diameter line may be necessary.

Be sure to clean the fireplace floor of any ashes or other foreign materials. It is recommended that the fireplace and chimney be examined and cleaned by a chimney sweep or other qualified person before you install the burner system, and annually thereafter.

Required Gas Pressure: The minimum inlet gas-supply pressure for the purpose of input adjustment is 5" for natural gas. The maximum inlet gas-supply pressure for this burner is 10.5" for natural gas.

Testing the Gas Supply System: The burner system and its individual shut-off valve must be disconnected from the gas supply piping system while performing any tests of the piping system at pressures in excess of ½ psig (3.5 kPa). The burner system must be isolated from the gas supply piping system by closing its individual manual shut-off valve during any pressure testing of the gas supply piping system at test pressures equal to or less than ½ psig (3.5 kPa). This is accomplished by closing the gas supply line valve, which is required by NFPA 54, section 5.54.

Burner size	Min. Fireplace Dimensions			BTU NAT.
	Width*	Depth	Height	
16/19"	22"	14"	18"	45k
18"	24"	14"	18"	65k
24"	30"	14"	18"	75k
30"	36"	14"	18"	80k
36"	42"	18"	18"	120k
42"	48"	18"	18"	130k
48"	54"	18"	18"	150k
60"	66"	18"	18"	170k

* This required width allows for centering of the system.

Minimum Free Opening Area of Chimney Damper for Venting (sq. in.)								
For Factory-Built Fireplaces *								
Chimney Height	16/19"	18"	24"	30"	36"	42"	48"	60"
15' (min.)	28	41	47	50	75	82	94	107
20'	26	37	42	45	68	73	85	96
30'	23	33	38	40	61	66	76	86

* For Masonry-Built Fireplaces; add 4 sq. in. to amount shown.

Important: For safe operation and proper performance of this product and to comply with certification, listings, and building code acceptances, use ONLY Peterson Real-Fyre® controls, parts, and accessories that have been specifically listed or certified for use with this burner system. Use of other controls, parts, or accessories is prohibited and will void all warranties, certifications, listings, and building code approvals, and may cause property damage, personal injury, and loss of life.

GLASS / GEMS QUANTITY DETERMINATION

Only the Real Fyre decorative media options listed below are approved for use with this product. Follow the guidelines to determine the recommended amount of decorative media needed to cover your burner / fill your fireplace floor. All decorative media options are purchased separately; contact your local Real Fyre dealer when ordering.

REQUIRED BASE MEDIA

Sand (included with burner) **MUST** first be placed to fill the burner pan.

PRIMARY MEDIA OPTIONS

A. Cover Burner Only (minimum requirement)

Glass/gems (purchased separately) **MUST** be placed to cover the burner (at minimum).

	Burner size							
	16/19	18	24	30	36	42	48	60
Recommended Amount of Glass/Gems	10 lbs	20 lbs	20 lbs	20 lbs	40 lbs	40 lbs	40 lbs	50 lbs

- OR -

B. Fill Entire Fireplace (optional)

Glass/gems (purchased separately) can be placed to fill the entire fireplace floor. Determine the correct amount needed (via online calculator or manual formula).

A calculator is available online to determine the correct media amount needed. Visit realfyre.com/fyre-glass-calculator/ or simply scan the QR code on the right.



Alternatively use the charts and steps 1-5 below.

Important: The height of glass media directly above the burner **MUST NOT** exceed 1". The website calculation (or formula below) allows for this requirement.

Determine the volume of area to be filled, then subtract a portion of the burner's volume. Finish by dividing by the glass/gems coverage amount.

Burner Volume to be Subtracted (cu. in.)							
Burner Size							
16/19	18	24	30	36	42	48	60
125	175	225	300	394	475	534	713

Glass/Gems Coverage Amount
16 cubic inches per lb

1. Determine the square area of the fireplace floor.
2. Multiply amount by 2 (for required 2" cubic height).
3. Subtract portion of burner's volume (see chart).
4. Divide by coverage amount: 16.
5. This is the number of pounds needed.

Example using G45-2-GL-24 in see-thru rectangular fireplace:

Volume Formula: $W \times D \times H$

Width: 32" Depth: 14" Height: 2" (set height)

1. $32 \times 14 = 448 \text{ sq. in.}$
2. $448 \times 2 = 896 \text{ cu. in.}$
3. $896 - 225 \text{ (per chart above)} = 671 \text{ cu. in.}$
4. $671 / 16 \text{ (per chart above)} = 42 \text{ lbs (rounded)}$

SECONDARY MEDIA OPTIONS (optional)

Secondary options such as river stones / fyre spheres / glass nuggets (purchased separately) may also be placed on top of the glass media.

INSTALLATION

The damper clamp with hex bolt (Fig. 6-1) is provided as a means to prevent full closure of the damper blade. The clamp is easily attached to most damper blades with pliers or a wrench, and must be permanently installed. The clamp is designed to prevent accidental closure of the damper when installed as illustrated (Fig. 6-2 and Fig. 6-3). Should the clamp not fit, or fail to provide the permanent vent opening listed in the table found above, have a permanent stop installed, remove the damper blade, or have the damper cut to provide the minimum permanent opening required.

Note: These are minimum damper opening specifications. The damper must be completely opened when operating this gas appliance to achieve the best ventilation possible.

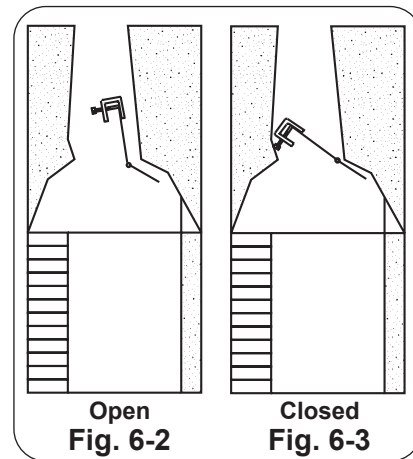
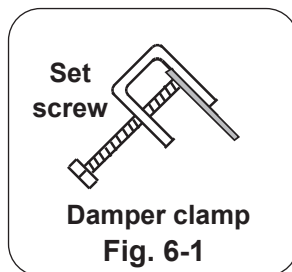

INSTALLING THE BURNER

The Real-Fyre burner system must be installed by a qualified professional service technician. Instructions must be followed carefully to ensure proper performance and full benefit from the burner system. **This burner system is designed and labeled for natural gas. Check to be sure natural gas is supplied to the fireplace. Fireplace floor must be level, clean, and smooth.**

WARNING: Failure to position the parts in accordance with these diagrams or failure to use only parts specifically approved with this appliance may result in property damage or personal injury.

REFER TO THE PARTS LIST WHEN FOLLOWING THESE INSTRUCTIONS.

The burner pan is supplied with a fuel injector for natural gas. **The fuel injector must be used in ALL installations.** The fuel injector has a precisely sized orifice to ensure only the proper quantity of gas enters the burner. This allows maximum performance and gas conservation.

1. MAKE SURE THE FIREPLACE GAS SUPPLY IS TURNED OFF.
2. Locate the gas-supply stub inside the fireplace and remove the cap, if attached (see Fig. 6-4).

CAUTION: When removing the cap, make sure the stub does not turn, loosening the connection inside the wall.

3. Attach the small adapter (Item 3C) to the fuel injector on the burner pan, using a pipe compound resistant to all gases. Tighten securely. **DO NOT REMOVE THE FUEL INJECTOR.** Then attach one end of the flex connector (Item 3B) to the small adapter. Tighten securely.
4. Place the burner system into the fireplace so that it is centered.

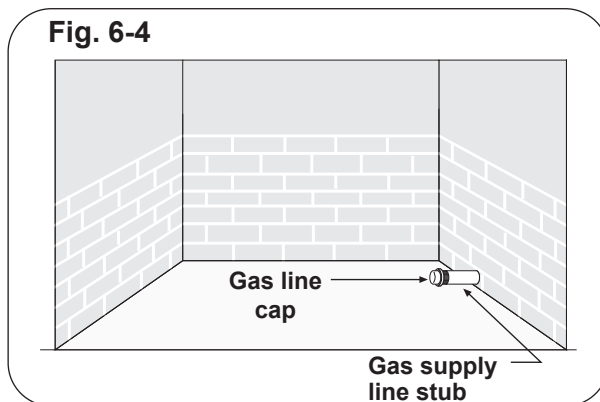

INSTALLATION (cont.)

- 5. Be sure gas to the fireplace is off.** Attach the large adapter (Item 3A) to the gas-supply stub using a pipe compound resistant to all gases. Tighten securely. Then attach the open end of the flex connector to the large adapter. Tighten securely. Ensure the pan rests level on the fireplace floor after connection. Adjust the pan if necessary.
- 6. LEAK TEST:** Follow the appropriate LIGHTING INSTRUCTIONS for your model to ignite the burner. Test at all connections for leaks using the appropriate soapy water solution. If bubbles appear, a leak is present. Turn off the gas and tighten at all connections. Repeat until no leaks are present. If a leak persists, turn off the gas supply and contact the local gas company or dealer. NEVER USE A FLAME TO CHECK FOR LEAKS.

Turn off the gas supply and allow unit to completely cool prior to proceeding.

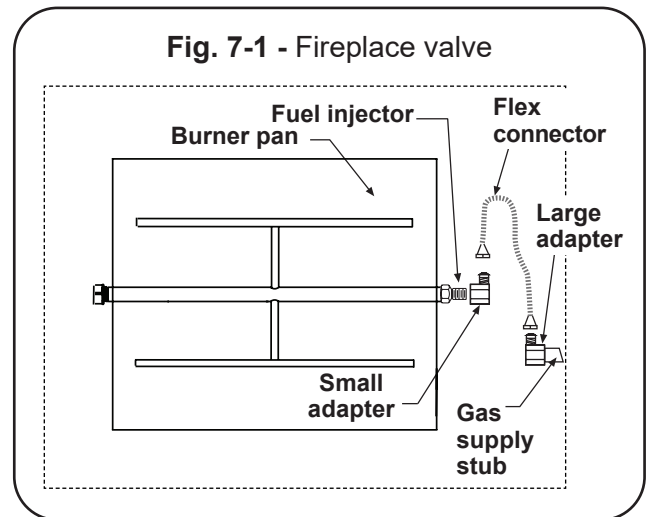

GLASS / GEMS PLACEMENT

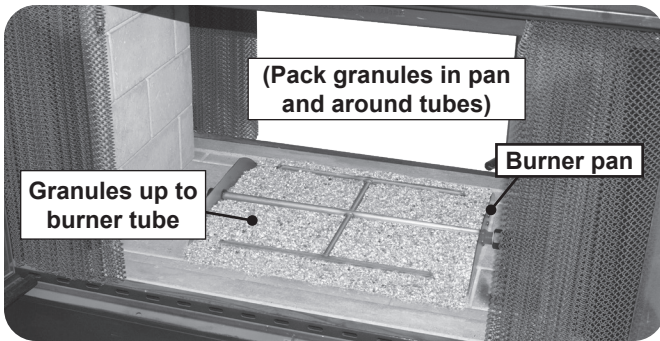

Fig. 8-1

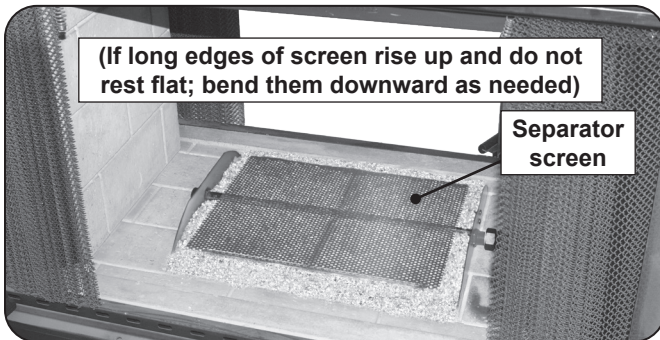

Fig. 8-2

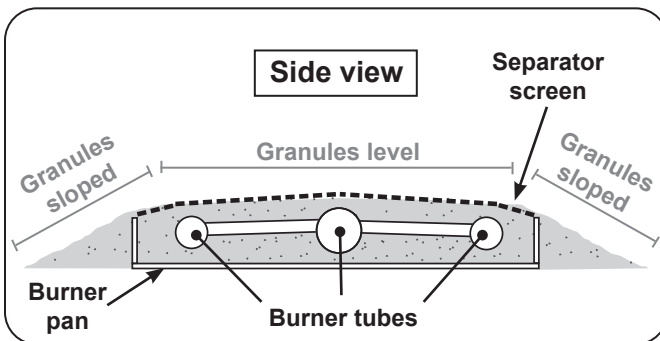

Fig. 8-3

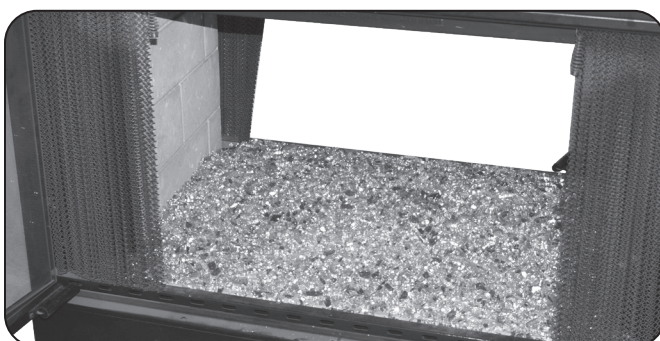

Fig. 8-4

BURNER PREPARATION

After hooking up the burner to the fireplace gas supply, the decorative media (granules and glass / gems) must be added for the burner to function as designed.

Note: Installation is the same for glass and gems. Glass shown here. Only use sand granules (on natural-gas burners) as a base for the glass.

WARNING

The burner must be **OFF** (fully extinguished) before pouring media onto the burner.

GRANULE PLACEMENT

1. Pour the granules into the pan until they just cover the burner tubes. Then pack the granules in the pan and around the burner tubes. Add additional granules as needed to end with the granules **level** with the top of the burner tubes. Slope the granules in the front portions of the pan. See Fig. 8-1 and Fig. 8-3.
2. Place the separator screen over the granules such that the long edges secure over the outside burner tubes, as shown in Fig. 8-2 and 8-3. If the long edges of the screen rise up and do not rest flat, bend them downward as needed.

Note: The screen must correctly rest onto the burner pan. If it sits too high; remove some of the granules to ensure a proper fit. **DO NOT** allow for any granules to be above the screen.

GLASS / GEMS PLACEMENT

CAUTION: Glass pieces may have sharp edges. Be careful handling the glass. Use hand protection, such as gloves, if necessary.

1. Pour the glass / gems directly on top of the granules and screen so that the burner pan is covered completely and evenly. Do not exceed a 1" depth directly above the overall surface of the burner.

Note: At this stage the burner will function as designed; however, more glass / gems may be added around the burner for decorative purposes.

2. Add additional glass / gems around the burner pan as desired (Fig. 8-4).

OPERATING THE BURNER SYSTEM - LIGHTING AND EXTINGUISHING

FOR YOUR SAFETY, READ BEFORE LIGHTING

WARNING: If you do not follow these instructions exactly, a fire or explosion may result, causing property damage, personal injury, or loss of life.

- A. BEFORE LIGHTING**, smell all around the burner system area for gas. Be sure to smell next to the floor because some gas is heavier than air and will settle on the floor.
- B. IF YOU SMELL GAS:**
- Shut off the gas to the appliance.
 - Extinguish any open flame.
 - If odor continues, keep away from the appliance, and immediately call the gas supplier or fire department.
- C.** Use only your hand to push in or turn the gas control knob. Never use tools. If the knob will not push in or turn by hand, don't try to repair it. Call a qualified service technician. Force or attempted repair may result in fire or explosion.

LIGHTING THE BURNER SYSTEM

1. Lay a lighted long-stem match on the surface of the embers near the gas inlet (**do not hold the match in your hand**) or use a lighted long-necked butane lighter.
2. Slowly turn the fireplace remote valve to the **ON** position. The log set should light.
3. If the log set does not light before the match goes out, immediately turn the valve off.
4. Wait approximately five (5) minutes to clear out any gas, and repeat steps 1-3 above. Smell for gas including near the floor. If you smell gas, stop and follow step B above. If you don't smell gas, proceed.
5. If the log set fails to light again, turn off the valve and contact the dealer or gas supplier.

TURNING OFF THE BURNER SYSTEM

1. To extinguish; simply turn the valve to the **OFF** position. Be sure the valve is turned completely off to avoid any gas leakage.

Please use this page to record any information that you may want to have at hand.

MAINTENANCE

Once installed and operating properly, your Real-Fyre® burner will require regular maintenance. You should inspect your burner for the following:

1. Moisture may cause the glass / gems in your burner pan to settle. To improve the burn, follow these tips:
 - a. Settling of glass / gems - Using a screwdriver or flat-blade knife, carefully stir the glass, loosening the material. Clear up any spills.
2. **Insects and burner blockage** - Check the burner ports and burner orifice, to make sure they are free from debris. Blocked burner ports and orifices may result in a fire.

CLEANING

Dust, carpet fibers, paper, spider webs, pet hair, etc. in the fireplace or on the burner assembly can affect operation of the burner. Vacuum or use compressed air from a can or compressor to clean out the burner assembly, and burner orifices.

SERVICE

While some minor service conditions can be handled by the owner of the burner, a qualified professional service technician should be called to maintain and service your glass burner. In addition, a periodic examination and cleaning of the solid-fuel-burning fireplace venting system should be conducted by a qualified professional service technician. The TROUBLESHOOTING section of these instructions serves as a guide for ensuring optimum performance of your burner.

To protect your investment in your Real-Fyre® gas fireplace burner system and keep it operating safely for years to come, maintain, clean, and inspect it regularly. We recommend following these instructions at the beginning of each fireplace season and as needed throughout the year, depending on your usage pattern and the environmental conditions in your home.

- Check and readjust the burner orifice.

FLAME DESCRIPTION

Observe the flames. The flames should be blue at the base and a combination of blue / yellow at the body and tips. The flames should be 16" to 18" tall. (See Figure 11-1). Inspect the flames periodically. If flames appear different, contact a qualified professional service technician or your gas supplier to correct the problem.



Fig. 11-1

TROUBLESHOOTING

SYMPTOM	CAUSE	SOLUTION
<p>1. Smoking and/or sooting</p> <p>(IMMEDIATELY STOP USING. Call your gas supplier or another qualified professional installer or service agency.)</p>	A. Poor draft or downdraft	A. Check for chimney blockage. Be sure chimney is at least 3' taller than anything within 10' of it in all directions. If not, consult a chimney sweep. Chimney cap or fan may help. Under severe conditions, you may need to open a window near the fireplace about 1" to 2" when burning the unit.
	B. Damper closed	B. Open damper fully when operating burner system.
	C. Burner is positioned too close to the front of the firebox	C. Move burner system to the center of the firebox.
	D. Improper glass/gems placement or amount	D. See PLACEMENT OF GLASS / GEMS section.
<p>2. Low flame</p>	A. Incorrect decorative media for type of gas used	A. Consult your dealer for proper set.
	B. Insufficient gas supply	B. Check gas pressure (Read D. - F. of IMPORTANT PRE-INSTALLATION AND FIREPLACE SAFETY INFORMATION section, & <u>check with local gas company</u>).
	C. Blockage or kink in connector kit, plumbing, or burner orifice	C. Clean out blockage. If connector kit is kinked, replace it.
	D. Valve not fully open	D. Open valve fully.

TROUBLESHOOTING (cont.)

SYMPTOM	CAUSE	SOLUTION
3. Uneven flame distribution (Lower at one end of the burner)	A. Clogged or blocked portholes	A. Clear out burner ports.
	B. Insufficient gas pressure and/or supply	B. Check gas pressure (see Section 2, B of this table).
	C. Decorative media may be packed down too tightly	C. Loosen media around burner pipe by running a kitchen knife along both sides of the pipe. Even out media in burner pan.
	D. Auxiliary shutoff valve partially closed	D. Open valve fully. Usually you will find this along the wall 3' from the fireplace.

WARRANTY

PETERSON VENTED DECORATIVE GAS APPLIANCE LIMITED WARRANTY

R.H. Peterson Co. ("RHP") warrants your Real Fyre® vented decorative gas appliance to be free from defects in material and workmanship.

RHP vented refractory gas logs are warranted for **as long as the original purchaser owns them (lifetime) when used indoors and for THREE (3) YEARS when used outdoors.**

RHP vented fiber-ceramic blended gas logs are warranted for **FIVE (5) YEARS when used indoors and for THREE (3) YEARS when used outdoors.**

RHP **indoor** vented gas log burners and stainless steel burners (excluding controls) are warranted for **TEN (10) YEARS.**

RHP **outdoor** vented stainless steel burners (excluding controls) are warranted for **FIVE (5) YEARS.**

The **SPK-26** is warranted for **THREE (3) YEARS** and **APK-17** (including -17 valve) is warranted for **TWO (2) YEARS.**

All other valves, pilots, and controls are warranted for **ONE (1) YEAR** (excluding batteries).

RHP glass, gems, and nuggets are warranted for **TEN (10) YEARS.**

A COPY OF YOUR SALES SLIP FOR PROOF OF PURCHASE IS REQUIRED

This warranty applies to the original purchaser for products which are installed in the United States or Canada and which are operated and maintained as intended for single family residential usage. This warranty is valid only with proof of purchase, commences on the date of purchase, and terminates (both as to original and any replacement products) on the anniversary date of the original purchase of the product per the above schedules.

This warranty covers defects in material and workmanship. This warranty **does not** cover parts which become defective as a result of negligence, misuse, use not in compliance with the Installation and Owner's Manual, accidental damage, improper handling, improper storage, improper installation, **lack of required routine maintenance** (as specified in the Installation and Owner's Manual), electrical damage, local gas impurities or failure to protect against combustible materials. Product must be installed (and gas must be connected) as specified in the Installation and Owner's Manual by a **qualified professional installer**. This warranty **does not** apply to rust, corrosion, oxidation, or discoloration unless the affected part becomes inoperable. RHP products including valves, pilots and controls, are designed and certified to be used as a system. Modifications to products which are not specifically authorized will void this warranty and could render the product to be unsafe. Burners, valves, parts, accessories, remotes, etc. used with this product must be RHP products or this warranty is void.

Warranted items will be repaired or replaced at RHP's sole discretion. This warranty **does not** cover labor or labor related charges, except as provided by separate specific written programs from RHP. All repair work must be performed by a qualified professional service person and requires prior approval of RHP.

RHP may require the defective product or part to be returned to the factory to determine the cause of failure. RHP will pay freight charges if the product or part is determined to be defective. This warranty does not cover breakage in shipment from our independent distributor to its customer if the damage is determined to have occurred during that shipment.

This warranty specifically excludes liability for **indirect, incidental, or consequential** damages. Some states and provinces do not allow the exclusion or limitation of incidental or consequential damages, so the above exclusion may not apply to you. This warranty gives you specified legal rights, and you may have other rights that vary from state to state or province.

For additional information regarding this warranty, or to place a warranty claim, contact the RHP dealer where the product was purchased.

When contacting your RHP dealer or the R.H. Peterson Co., please provide the following information:

- Your name, address, telephone number, e-mail
- Sales receipt showing where purchased and date purchased
- Model number, serial number of product, date code
- Relevant information: installer, additions, repairs, when defect was first noted

**TO REGISTER YOUR PRODUCT ONLINE GO TO: WWW.RHPETERSON.COM,
AND CLICK ON PRODUCT REGISTRATION. THANK YOU FOR YOUR PURCHASE.**